

ADVANCED AND EVER ADVANCING **MITSUBISHI ELECTRIC**

 **MITSUBISHI**
PROGRAMMABLE CONTROLLERS
MELSEC-F



FX

FX-10DU-E

OPERATION MANUAL

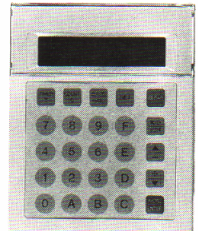

Thank you for choosing the Mitsubishi Micro PC data access module.

Please read this manual carefully and make sure the specifications are completely understood so that the equipment is used to its optimum.

This manual should be forwarded to the end user.

CONTENTS

	PAGE
1. INTRODUCTION	1
2. BASIC FUNCTIONS AND ADDITIONAL FUNCTIONS	2
3. SPECIFICATIONS, EXTERNAL DIMENSIONS AND INSTALLATION	4
4. KEY LAYOUT AND SCREEN SYMBOLS	6
5. BASIC KEY OPERATIONS	8
6. SAMPLE SCREEN DISPLAY	10
7. SAMPLE OPERATION (BASIC FUNCTION)	12
8. SAMPLE OPERATION (SETTING OF A CONSTANT CHANGEABLE DEVICE)	13
9. SAMPLE OPERATION (SETTING OF A ENTERED MONITOR DEVICE)	14
10. SPECIAL DEVICE MONITORING	15
11. ERROR DISPLAY CONTENTS AND PROCESSING	16

1. INTRODUCTION

- The FX-10DU Data Access Unit is installed on the surface of the control panel. It is linked by a dedicated connector cable to an FX series PC inside the control panel. The data access unit is used to display the current values of timers, counters and data registers, as well as to change set values.
- This unit has an LCD (16 letters × 2 lines) illuminated by a long-life LED backlight. Power is supplied from the PC through the dedicated cable previously mentioned.
- Since different applicable cables are used for FX₀ series PCs and FX series PCs, make sure to always use the proper cable, as shown in the table on the right of this page.
- This unit is an easy-to-use, small-size display unit, whose specifications and functions are the same for all PCs.

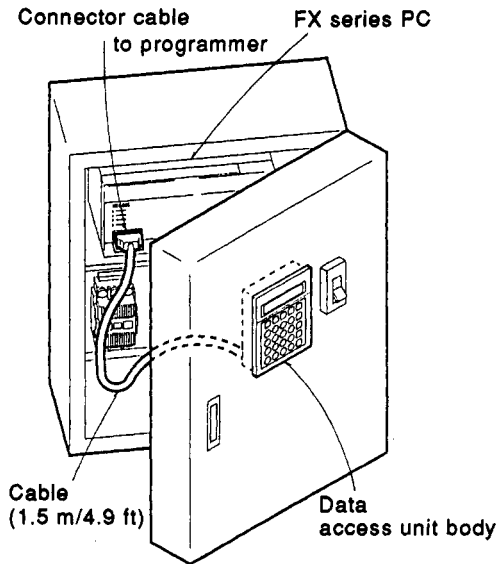

For FX series PCs	FX-20P-CAB
For FX₀ series PCs	FX-20P-CAB0 or FX-20P-CAB and FX-20P-CADP

Note: All cables are supplied separately.

2. BASIC FUNCTIONS AND ADDITIONAL FUNCTIONS

The basic functions of this unit monitor the current values and change the set values of a timer T, counter C and data register D (including file registers for FX series PCs) at the operator level.

<How to set T and C>

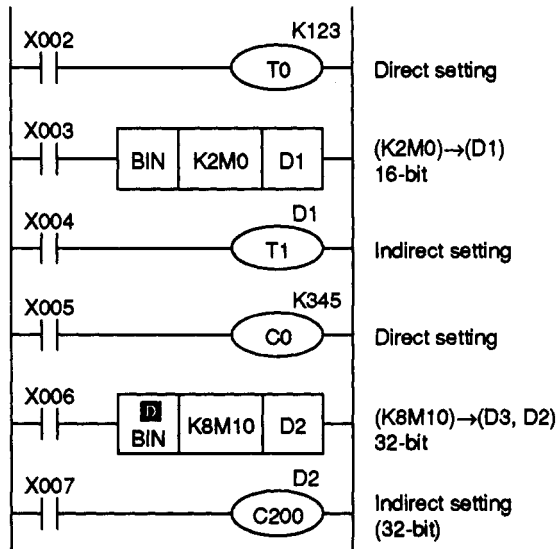

In indirect setting, a value written in data register D1 or (D2, D3) is the set value for T1 and C200.

<Basic functions>

- (1) The current value and the set value of a timer or counter can be displayed, and the set value can be changed. In indirect setting using a data register, the data register number and contents can be changed.
- (2) The current values of data registers (including file registers for FX series PCs) can be displayed, and the contents can be changed.
- (3) It is impossible to display current values or to change set values if a keyword of level A or C has been entered in the PC. In this case, change the keyword to that of level B. This makes it possible to change any set value (see page 16 for error message). However, for a device to be accessed it must be specified in the initial setup of the data access unit. These setups and additional functions are explained overleaf. There are restrictions for changing set values when the PC is using certain memory types or if the PC is in RUN/STOP. These restrictions are identified in the table overleaf.

2. BASIC FUNCTIONS AND ADDITIONAL FUNCTIONS

Additional functions are also available by doing initial settings at the design stage. These additional functions are used to prevent incorrect writing by the operator and to make operations easier.

<Additional functions> Initial setting

- (1) The range of the device numbers of T, C and D where the operator can change the set value can be designated. (Setting of constant changeable device)
- (2) Up to a total of 8 preset device numbers for T, C or D can be entered in advance. By using this function, devices can be easily selected and displayed, without keying in the device number. (Setting of entered monitor device)
- (3) Designate D8040 as the entered device monitor and make M8047 the drive on the PC side. This allows up to eight SFC operating condition numbers to be displayed in ascending order. (Dynamic monitor function)
- (4) Designate D8049 as the entered device monitor and make M8049 the drive on the PC side. This allows the operating condition numbers from S900 to S999 to be displayed. (Annunciator function)
- (5) Designate D8013 as the entered device monitor and install the cassette for a real-time clock in the FX PC. This allows the year, month, day, day of the week, hour, minute, and second to be displayed. (Time display function)

Whether setting changes are permitted or not

- : Permitted
 × : Not permitted
 Δ : Conditionally permitted

(Memory protect switch OFF)

		PC STOP				PC RUN			
		FX ₀	FX			FX ₀	FX		
			RAM	EEPROM	EPROM		RAM	EEPROM	EPROM
T	Value of K	○	○	Δ	×	○	○	×	×
•	Contents of D	○	○	○	○	○	○	○	○
C	Number for D	○	○	Δ	×	○	○	×	×
	Data register contents	○	○	○	○	○	○	○	○
	File register contents	-	○	Δ	×	-	○	×	×

3. SPECIFICATIONS, EXTERNAL DIMENSIONS AND INSTALLATION

Power supply	5 VDC \pm 5% 220 mA (Supplied from the PC)
Ambient temperature	0 to 50 °C
Ambient humidity	35 to 85% RH (without condensation)
Vibration resistance	Conforms to JIS C0911 (10 to 55 Hz, 0.5mm/0.02 in(max. 2G), 2 hours each in the X/Y/Z directions)
Shock resistance	Conforms to JIS C0912 (10G, 3 times each in the X/Y/Z directions)
Environment	Free of corrosive gases and airborne dust
Keyboard	25 keys (membrane switch with 0.15/0.006 to 0.45 mm/0.018 in stroke)
Display unit	LCD with LED backlight, 16 letters \times 2 lines
Applicable PCs	FX0, FX series PCs. However, an FX-20P-CADP cable adaptor (0.3 m/0.98 ft) or FX-20P-CAB0 cable (1.5 m/4.92 ft) is necessary for FX0 series PCs.

<Supplementary note> Built in EEPROM

Settings in additional functions (setting of constant changeable device and setting of entered monitor device) are written to the EEPROM built into this unit. When the power is turned ON again after being cut OFF, the screen which was monitored when the power supply was cut OFF is redisplayed. This is called the resume function. The resume function uses the incorporated EEPROM. Up to about 100,000 times of rewriting using the EEPROM can be done.

3. SPECIFICATIONS, EXTERNAL DIMENSIONS AND INSTALLATION

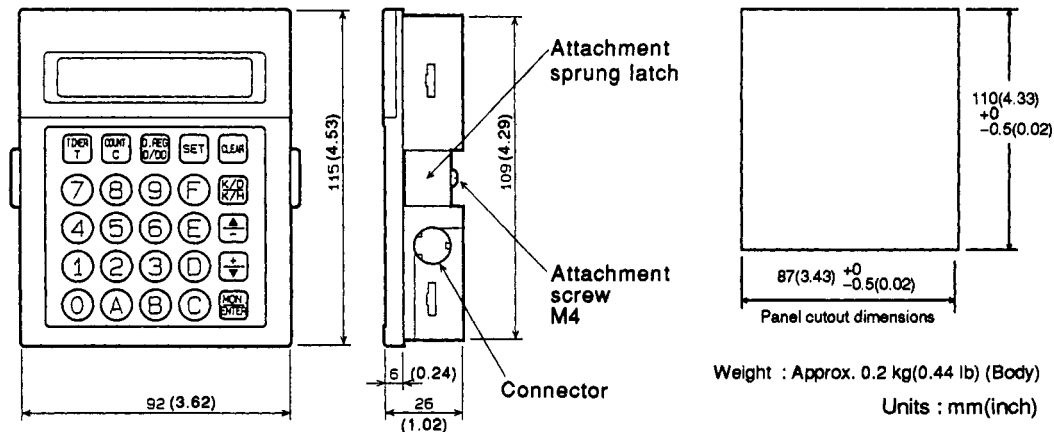

<Installation method>

- (1) Remove the attachment sprung latch on the rear surface of the unit.
- (2) Insert this unit into the specified cutout.
- (3) Tighten the attachment sprung latch on the rear surface of the unit with the attachment screw, holding the control panel with the sprung latch and the peripheral part of the panel.
- (4) The screw tightening torque must be in the range from 3 to 5 kg·cm.
- (5) The thickness of the panel where this unit is installed must be 4 mm(0.16 in) or less.

<Connection method>

Use the correct cable to attach this unit to the PC programmer. Secure both ends of the cable so that excessive strain is not applied to the connectors.

<Connection example using an FX₀ PC and FX-20P-CADP cable adaptor>

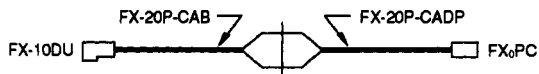

4. KEY LAYOUT AND SCREEN SYMBOLS

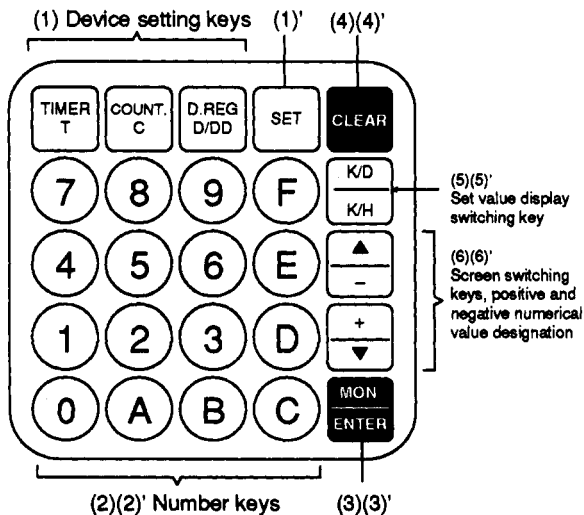

To carry out monitoring operations, press one of the device setting keys (1), the device number (2), and the [MON.] key (3). To monitor the contents of a 32-bit data register, press the [D/DD] key twice.) To change a set value, press the [SET] key (1)', the numbers to be set (2)', and the [ENTER] key (3)'.

<Special operation keys>



This key is used to clear incorrectly entered data or key operations, as well as switching through screen displays (see pages 8 and 9).



- This key is used after pressing the [SET] key to change the data register number used for indirect setting of the timer or counter.



- This key is used to switch the decimal/hexadecimal data register display.



These keys are used to increase and to reduce the device number being monitored in the monitor mode. These keys are also used to change the entry order of the entered device numbers to be monitored.



These keys are used to designate positive or negative values in the setting mode.



To designate a negative value, press the minus [-] key.

4. KEY LAYOUT AND SCREEN SYMBOLS



This is the screen for designated device monitor.



This is the screen for entered device monitor.



This is the screen for changing the set value of a designated device.



This is the screen for changing the set value of an entered device.

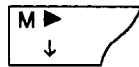

If a monitoring screen extends over two screens, an arrow is displayed. The two screens can be alternately displayed by pressing the [MON.] key.



Dxxx This indicates monitoring or set value changing of a 32-bit data register.

Kxxx This indicates the current value of a timer or counter. Changing the value by keying in cannot be done (see page 17).

Kxxx This indicates the set values of a timer or counter, and the contents (current values) of a data register. Values can be changed by pressing the number keys from 0 to 9.

Hxxx Hexadecimal numbers can be displayed and written in the data register by pressing the number keys 0 to F.

—■— These indicate the ON/OFF conditions of the output contact of the timer or counter.

R This indicates that the reset command of a timer or counter is activated, and that the OUT command is not activated in the case of a non-retentive timer. Please note this is not activated by high speed counters.

UP
DN These indicate the operating conditions (UP/DN) of a reversible counter.

- Pages 10 and 11 give screen display examples.

5. BASIC KEY OPERATIONS

This section shows the general key operations for monitoring and setting.

A sample operation is shown on page 12.

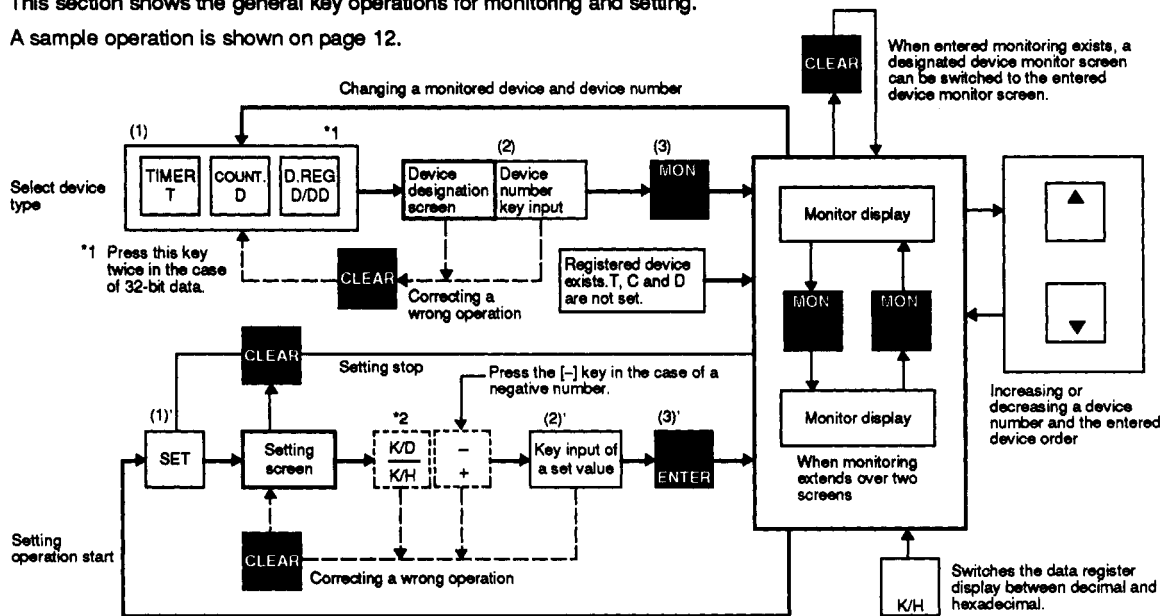

*2 In the case of a timer and counter : Press this key only when changing an indirect setting data register number.
 In the case of data register : Press this key only when inputting decimal values.

5. BASIC KEY OPERATIONS

This section gives the main points of the setting operations for additional functions. Sample operations are shown on pages 13 and 14.

This operation is generally done as the initial setting at the design stage.

<Setting of a constant changeable device>

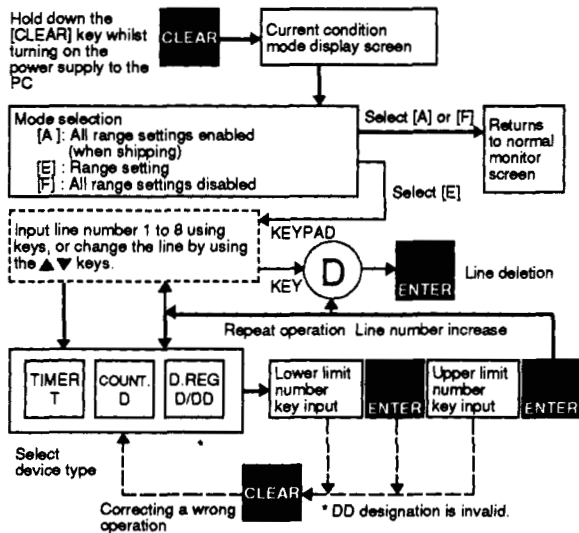

Press the [B] key to exit these setting modes.

<Setting of a entered monitor device>

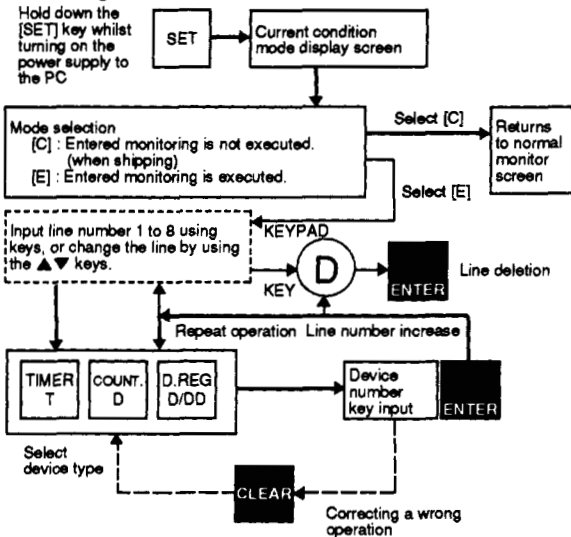

6. SAMPLE SCREEN DISPLAY

(1) Direct timer setting (16-bit counter is the same)

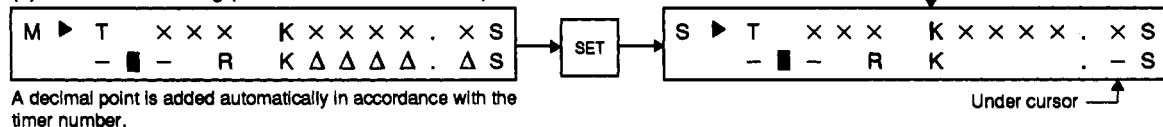

(2) Timer indirect setting (16-bit counter is the same)

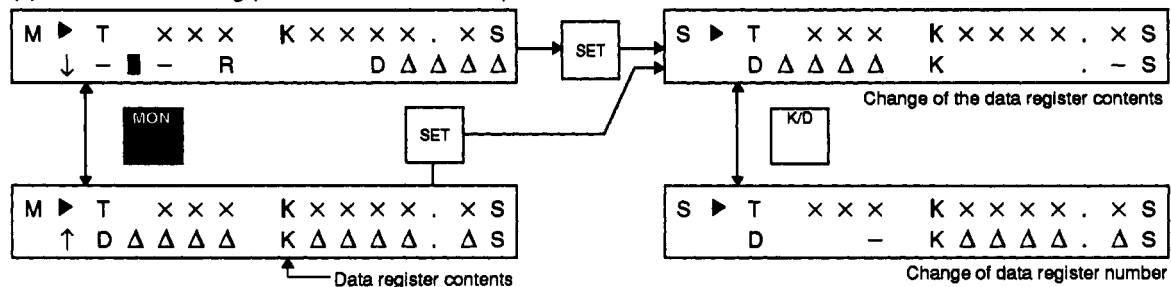

(3) 16-bit data registers

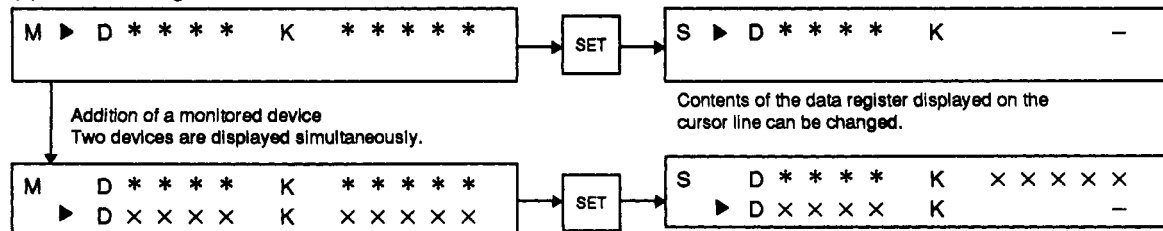

6. SAMPLE SCREEN DISPLAY

(4) 32-bit counter direct setting

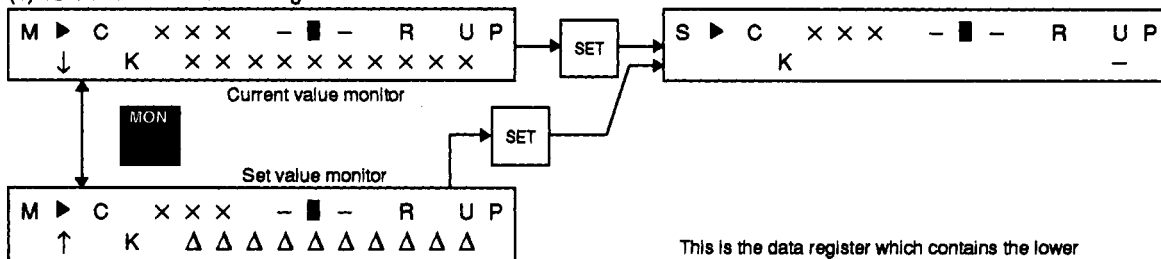

(5) 32-bit counter indirect setting

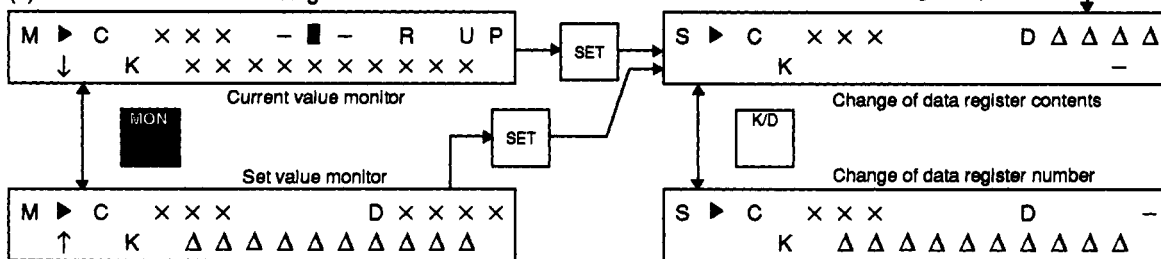

(6) 32-bit data registers

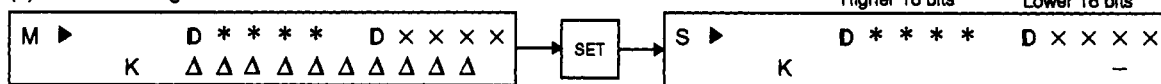

If DXXXX is designated, D**** is displayed automatically as the higher number following this.

7. SAMPLE OPERATION (BASIC FUNCTION)

This section gives a sample procedure when monitoring all devices and setting the changes of all devices based on the sequence described on page 2.

Connect the transmission cable, and turn ON the PC power supply. Use the RAM memory for the PC (use the EEPROM for an FX0), and switch the RUN/STOP input to RUN.

Initial screen (for 3 seconds)

```

M E L S E C   F X - 1 0 D U
                V - X . X X
    
```

The monitor screen selected last time is displayed.

```

M ▶
    
```

TIMER T 0 MON

Turn Input X2 ON.

```

M ▶ T   0   K X X X X . X S
- || -   K   1 2 . 3 S
    
```

SET 2 3 4 ENTER

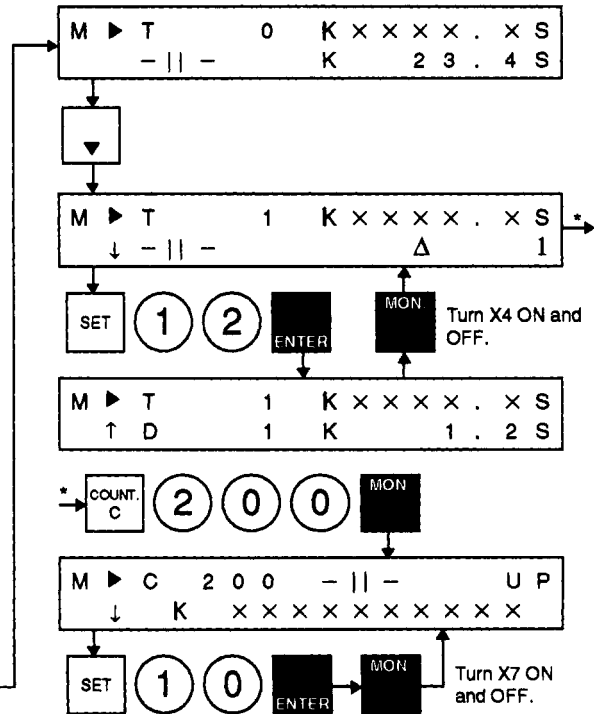

8. SAMPLE OPERATION (SETTING OF A CONSTANT CHANGEABLE DEVICE)

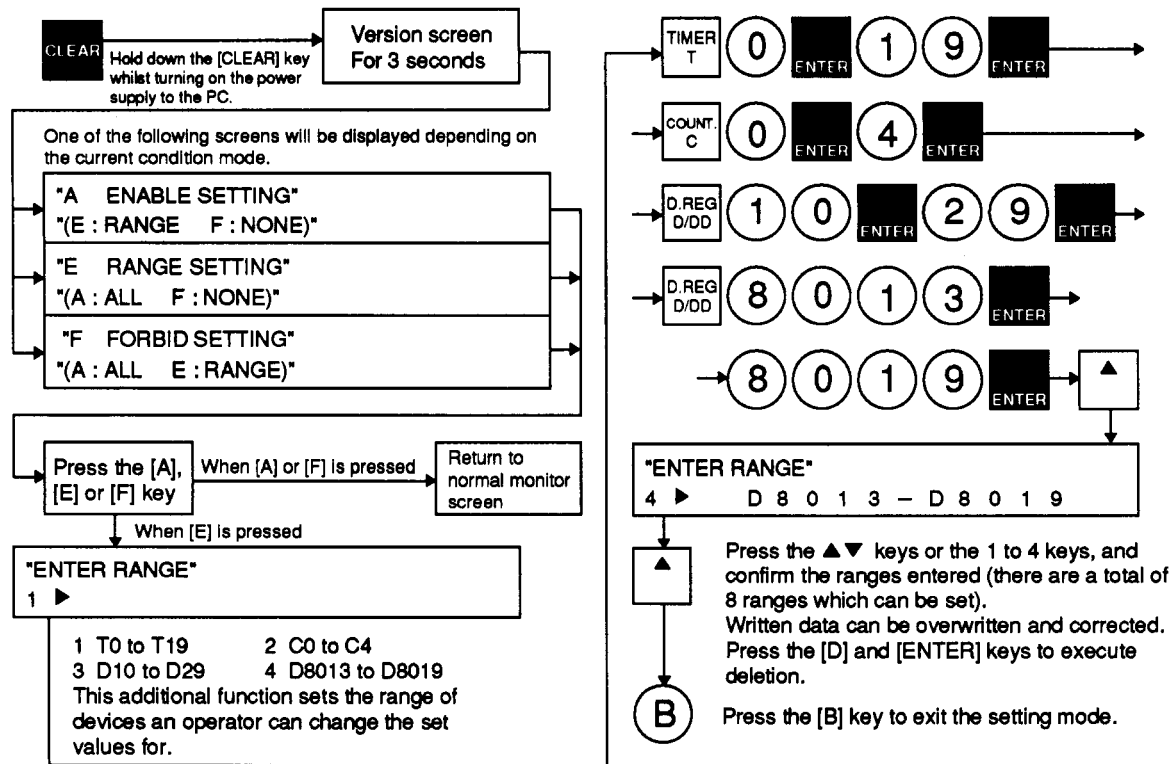

9. SAMPLE OPERATION (SETTING OF A ENTERED MONITOR DEVICE)

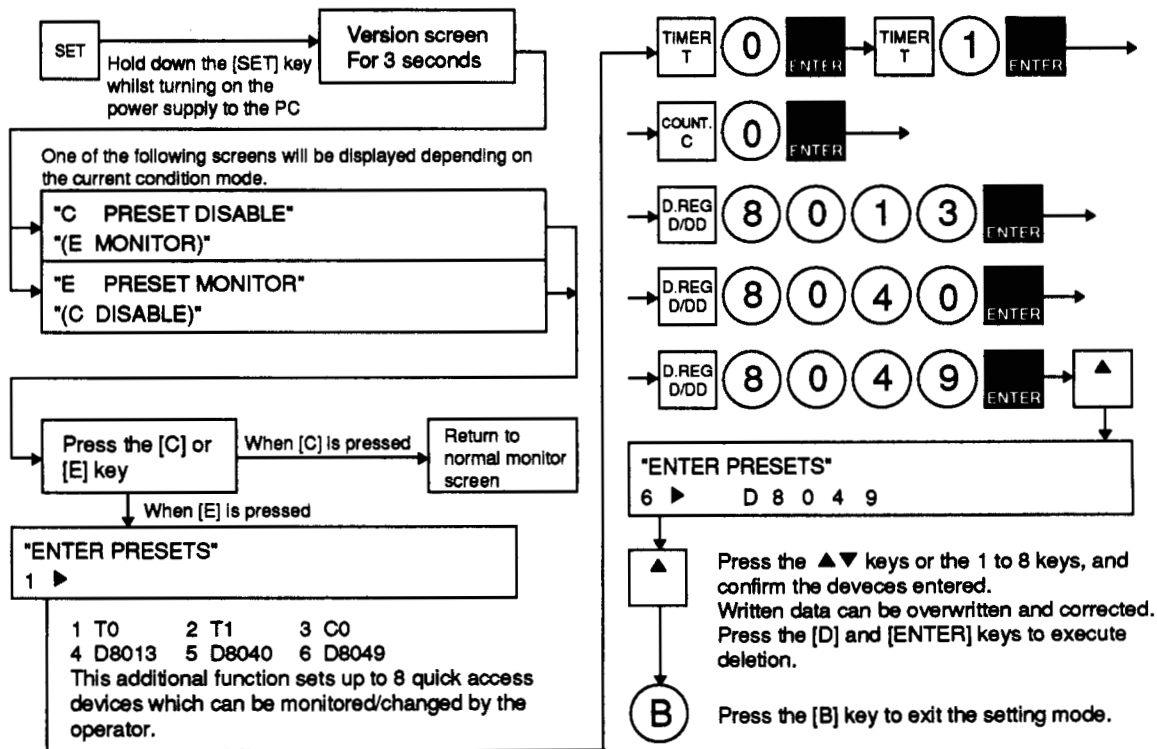

10. SPECIAL DEVICE MONITORING

This section shows how to execute special device monitoring.

Initially setup requires some program additions at the design stage. By doing so, the operator can easily monitor a corresponding device.

In this case, use the ▲▼ keys to switch and display sequentially.

If D8013, D8040, or D8049 is designated as the selected device, the monitoring screen is a special screen as shown below.

[1] Time display (D8013)

NO CLOCKCASSETTE
ON FX PC

A cassette for a real-time clock such as an FX-RTC, FX-RAM-8C, and FX-EEPROM-4C is not installed.

M ▣ ' 9 2 / 1 2 / 3 1 T H U
1 0 : 3 2 : 2 5

SET

ENTER

Pressing the [ENTER] key rounds the seconds display to the nearest thirty seconds

* For time setting, see page 18.

[2] SFC operating state monitor (D8040)

M ▣ S x x x S x x x
↓ S x x x S x x x

MON

The operating state number is displayed.

M ▣ S x x x S x x x
↑ S x x x S x x x

M ▣ M 8 0 4 7 O N

M8047 is not displayed on each screen.

[3] Annunciator monitor (D8049)

M ▣ ANNUNCIATOR MONITOR
S x x x

The lowest station number of the operating state numbers S900 to S999 is displayed.

M ▣ M 8 0 4 9 O N

M8049 is not displayed on each screen.

11. ERROR DISPLAY CONTENTS AND PROCESSING

Classifications	Messages	Contents and Processing
When the power supply is turned ON	PC COMMS ERROR	Communication with the PC cannot be established. Make sure the transmission cable is properly connected and turn ON the power supply. Do not connect the cable after turning ON the power supply.
	ENTER KEYWORD	The Axxxxxxx keyword (all operations prohibition) is entered in the PC. Change it to the Bxxxxxxx keyword (theft protection). As a result, all devices can be monitored, and set and current values can be changed.
When setting a device number	DEV NUM ERROR	When a non-existent device number is entered. Press the [CLEAR] key, and then input the correct number.
	NO CORRESPONDING PROGRAM	When the corresponding device is not used for a sequence program. Change the number.
When the [SET] key is pressed	ENTER KEYWORD	The Cxxxxxxx keyword (write disabled) is entered in the PC. Change it to the Bxxxxxxx keyword.
	DEV OUT OF RANGE	When attempting to set a device. Not specified in the range set by the additional function (see page 13) Press the [CLEAR] key, and then change the number.
	NONE	When attempting to set a device which does not exist in the sequence program held in the PC.
	MEMORY PROTECT-DISABLE TO SET	When an EPROM or EEPROM is used for the memory of the PC, and the memory protect switch is set to ON. Either turn OFF this switch or use a RAM.
	UNABLE TO SET	Writing cannot be done during PC RUN even when the EEPROM memory protect switch is turned OFF. Switch it to STOP (see page 3).

An FX peripheral device such as an FX-10P, FX-20P, A6GPP or a personal computer is necessary for changing keywords.

11. ERROR DISPLAY CONTENTS AND PROCESSING

SUPPLEMENTS

[1] Changing the current value of a timer or counter

When changing the set value of a timer or counter, use the following special operations:

- (1) Display the monitoring screen of the target timer or counter.
- (2) Press the [SET] key, and then press the [MON.] key.
- (3) As a result, an under cursor is displayed in the area of the current value display, and a numerical value can be written.
- (4) Press the [ENTER] key.

[2] Device number ranges

* When driving M8028

	Devices	FX ₀	FX
Timers	100 ms	T0 to T55	T0 to T199
	10 ms	T32 to T55 *	T200 to T245
	1 ms	—	T246 to T249
	100 ms Addition	—	T250 to T255
Counters	16-bit up	C0 to C15	C0 to C199
	32-bit up/down	—	C200 to C234
	32-bit high-speed up/down	C235 to C254	C235 to C255
Registers	General	D0 to D31	D0 to D511
	Special	D8000 to D8069	D8000 to D8255
	File	—	D1000 to D2999

11. ERROR DISPLAY CONTENTS AND PROCESSING

SUPPLEMENTS

[3] Time setting (only for the FX PC)

When current time is being monitored, the time of the real-time clock cassette installed in the PC can be changed by the following operations:

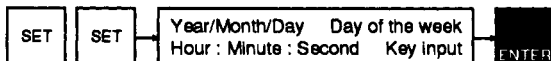

- (1) Input the year, month, day, day of the week, hour, minute, and second in accordance with the under cursor.

Example : December 25 (Friday), 1992

13:25:15

(9)(2) (1)(2) (2)(5) (5)

(1)(3) (2)(5) (1)(5)

- (2) Use the ▲▼ keys to move forward or backward.
- (3) For the corresponding days of the week and numerical characters, see the following table.

0	1	2	3	4	5	6
Sunday	Monday	Tuesday	Wednesday	Thursday	Friday	Saturday
SUN	MON	TUE	WED	THU	FRI	SAT

MEMO

Revisions

EDITION DATE	MANUAL NUMBER	REVISION
Feb.'93	JY992D34901A	First edition

Under no circumstances will Mitsubishi Electric be liable or responsible for any consequential damage that may arise as a result of the installation or use of this equipment.

All examples and diagrams shown in this manual are intended only as an aid to understanding the text, not to guarantee operation. Mitsubishi Electric will accept no responsibility for actual use of the product based on these illustrative examples.

Owing to the very great variety in possible applications of this equipment, you must satisfy yourself as to its suitability for your specific application.



MITSUBISHI ELECTRIC CORPORATION

HEAD OFFICE: MITSUBISHI DENKI BLDG MARUNOUCHI TOKYO 100 TELEX: J24532 CABLE MELCO TOKYO
HIMEJI WORKS: 840, CHIYODA CHO, HIMEJI, JAPAN

JY992D34901A
HI-IB-090-A (9301) (SEN) (A1)

Effective JAN. 1993
Specifications are subject
to change without notice.